

## R-1050-B (BURNOUT) PROGRAMMABLE ELECTRIC MUFFLE KILN USER MANUAL

### PRODUCT INTRODUCTION:

THIS R-1050-B (BURNOUT) ELECTRIC MUFFLE KILN WITH A PROGRAMMABLE 32-SEGMENT TEMPERATURE/TIME CONTROLLER HAS A SPACIOUS 11.5 CUBIC LITRE CHAMBER WITH A FORCED AIR-EXTRACTION SYSTEM (1 m<sup>3</sup>/min). THIS KILN IS ESPECIALLY DESIGNED TO BE USED FOR ALL BURNOUT PROCESSES (WITH OR WITHOUT FLASKS) USING ANY TYPE OF WAX, MOULD-MAKING AND DENTAL MATERIAL (INCLUDING ALL MATERIALS USED IN INVESTMENT CASTING) THAT REQUIRE TEMPERATURES OF UP TO 1,050°C/1,922°F. FOR YOUR SAFETY THIS KILN HAS A SAFETY MECHANISM THAT WILL DISCONNECT THE KILN'S POWER SUPPLY FROM ITS HEATING ELEMENT(S) IF THE KILN DOOR IS OPEN OR HAS NOT BEEN PROPERLY CLOSED. THIS KILN ALSO HAS A HOLE WITH A STAINLESS STEEL SHUTTER ON THE DOOR TO ALLOW YOU TO SEE YOUR ITEM(S) DURING THE ENTIRE FIRING PROCESS AND A DIGITAL OVER/UNDER TEMPERATURE DETECTION SAFETY SYSTEM TO HELP MAINTAIN A CONSTANT TEMPERATURE DURING THE ENTIRE SOAKING PROCESS. THIS KILN ALSO HAS A SMOOTHING CIRCUIT TO ALLOW THE PROGRAMMABLE CONTROLLER TO CORRECTLY READ AND STABILISE ELECTRICITY FLUCTUATIONS.

**Pic. 1 FRONT VIEW:**

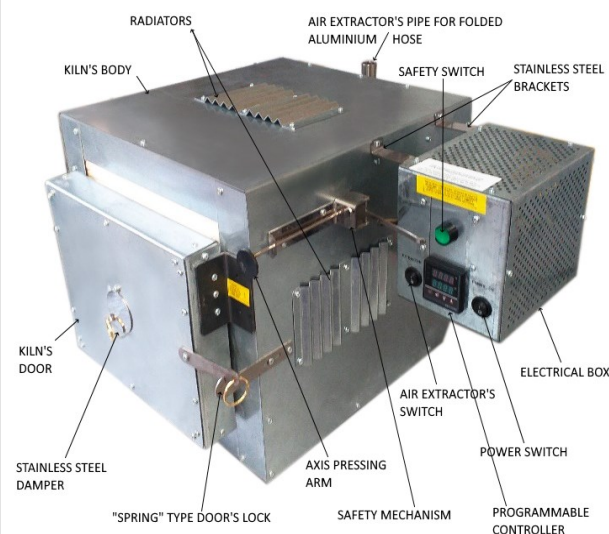

**Pic. 2 BACK VIEW:**

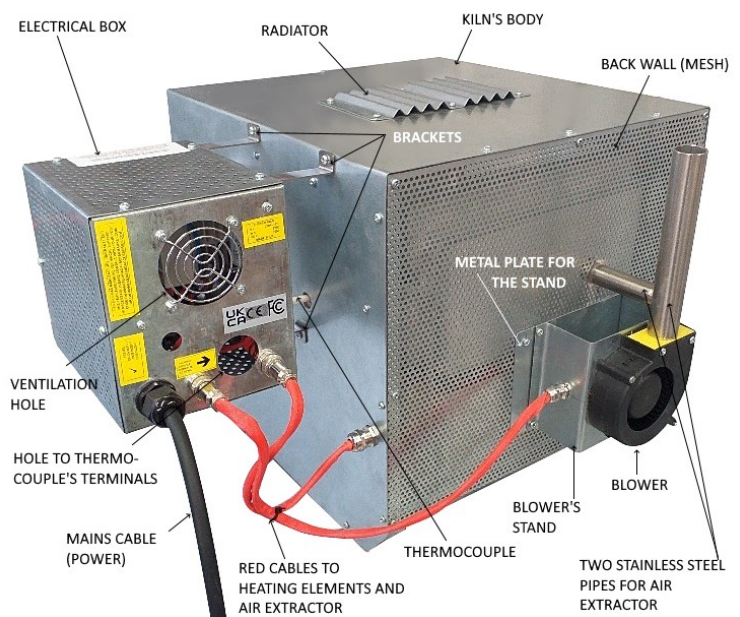

<b>MODEL:</b>	<b>R-1050-B</b>	<b>CALIBRATION:</b>	<b>YES</b>
<b>INPUT ON REQUEST:</b>	<b>115, 220 or 240 V</b>	<b>SOAKING PROCESS ACCURACY:</b>	<b>+/- 1°C</b>
<b>POWER:</b>	<b>2,700 WATT</b>	<b>SAFETY MECHANISM:</b>	<b>Yes</b>
<b>ESTIMATED MAXIMUM HEATING TEMPERATURE:</b>	<b>1,050°C / 1,922°F</b>	<b>TEMPERATURE RANGE:</b>	<b>ROOM TEMPERATURE - 1,050°C / 1,922°F</b>
<b>ESTIMATED HEATING TIME TO 1,050°C:</b>	<b>90 MINUTES</b>	<b>VENTILATION SYSTEM:</b>	<b>FORCED, AIR 1 M3/MINUTE</b>
<b>CONTROLLER TYPE:</b>	<b>PROGRAMMABLE 32 SEGMENT</b>	<b>CHAMBER'S DIMENSIONS MM (INCH):</b>	<b>200(w) x 290(d) x 200(h) 8" x 11.5" x 8"</b>
<b>CONTINUOUS WORKING TIME AT 1,050°C:</b>	<b>12 HOURS</b>	<b>KILN'S DIMENSIONS MM (INCH):</b>	<b>360(w) X 450 (d) X 360(h) (14" x 18" x 14")</b>
<b>CONTINUOUS WORKING TIME BELOW 1,000°C:</b>	<b>24 HOURS</b>	<b>WEIGHT:</b>	<b>35 KG</b>

Pic. 3

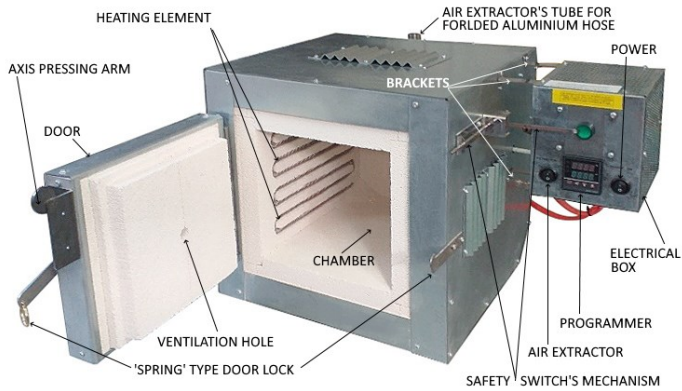

Pic. 4

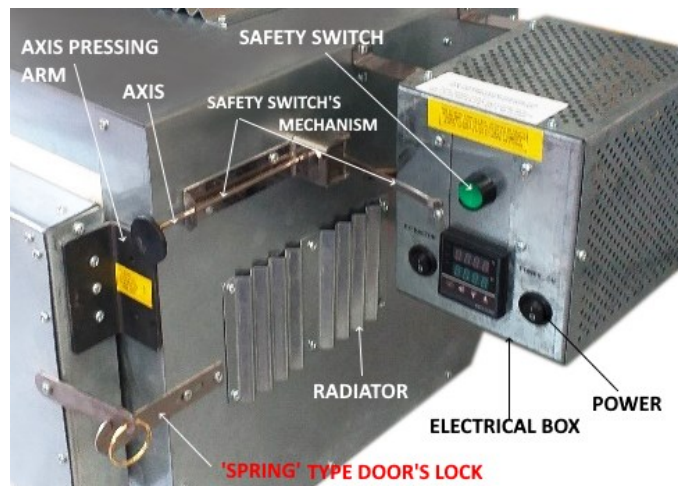

## PREPARATION:

- Remove the kiln from its original box.
- Put the kiln on a heat-resistant worktop such as a stand, stone plate, metal sheet or ceramic tiles. Please note that the worktop should be very stable and be able to hold 40 kg of weight for your safety.
- Open the kiln door and carefully remove all the accessories and packing materials from the chamber.
- Now start assembling the kiln by attaching the electrical box to the kiln's body (see Pic. 3). To do this:
  - ◆ Take the electrical box with 3 stainless steel brackets (Pic. 5) and attach all of them to the kiln's body as shown in Pics. 3, 7 and 8, using the screws supplied.

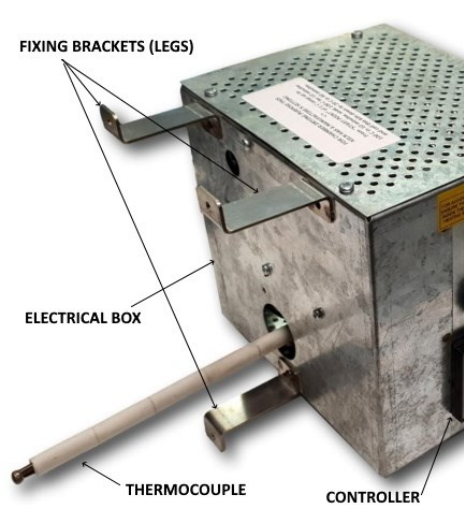

Pic. 5

If your kiln does not already have a lock attached to the door, find the two-part metal spring lock in the pack and attach it to the kiln door and body as shown in Pic. 6.

Pic. 6

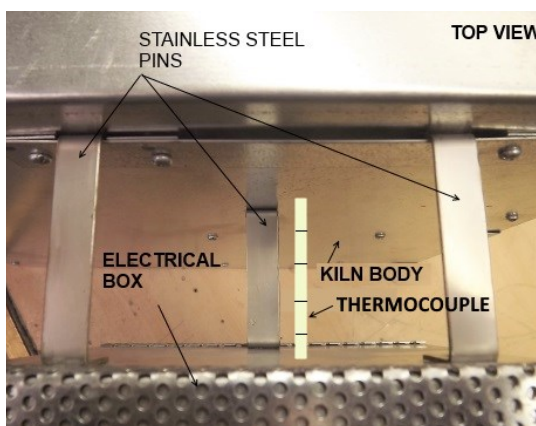

Pic. 7

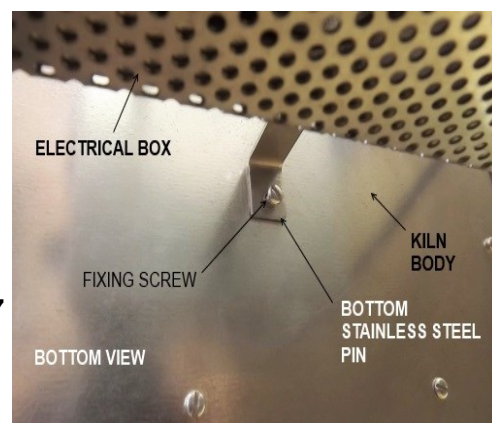

Pic. 8

Now you can connect the electrical box to your kiln's heating element(s) and fume-extraction system using the red cables, and then attach the safety-switch mechanism. To do this:

Pic. 9

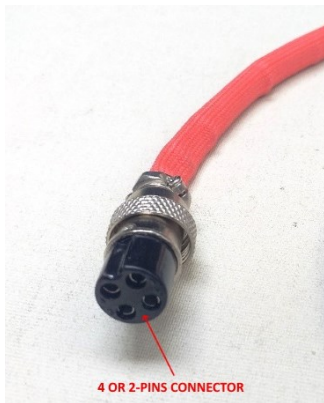

Pic. 10

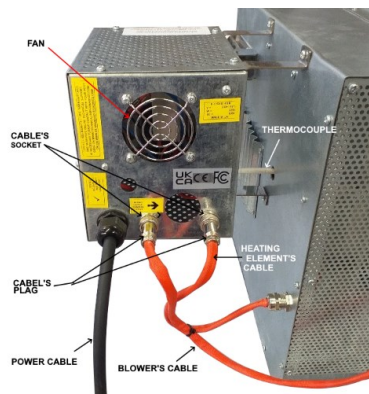

Pic. 11

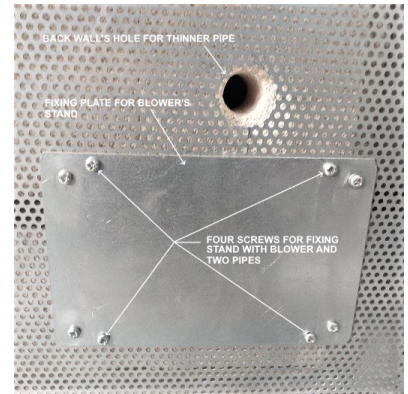

- ◆ Fix the blower (with two stainless steel tubes) onto the metal plate on your kiln's back wall (Pics. 11 and 12).
- ◆ Connect the red cables (Pic. 9) for the heating element and air extractor to their terminals (sockets) on the electrical box (Pic. 10).
- ◆ Now you need to attach the safety-switch mechanism to the kiln. This mechanism is important for your safety as it will disconnect all the heating elements inside the chamber if the door of your kiln is open or has not been properly closed. This decreases the risk of an electric shock arising from accidentally touching the elements using metal tongs, tweezers, accessories or your firing object(s). To do this:
- ◆ Take the ready-to-use mechanism from its pack and attach it to the kiln as shown in Pic. 13, using the two small screws supplied.

Pic. 12

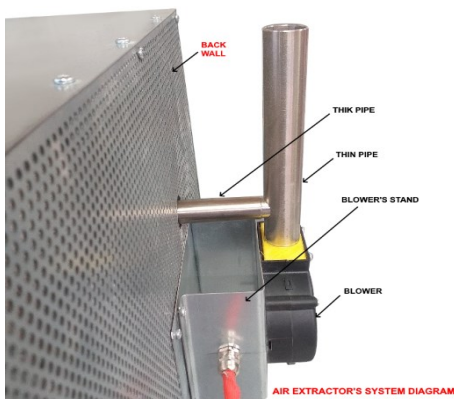

Pic. 13

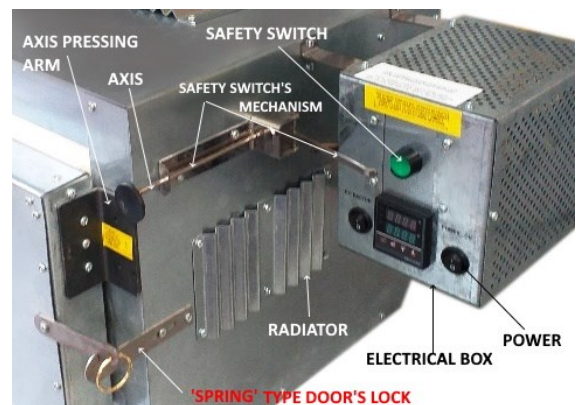

Pic. 14

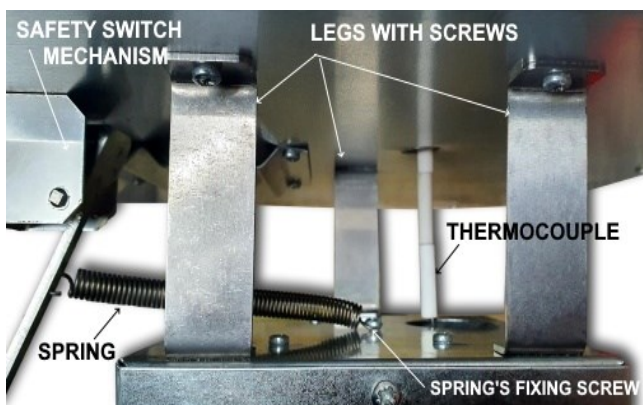

Pic. 15

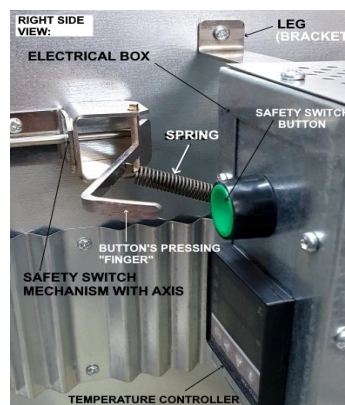

Pic. 16

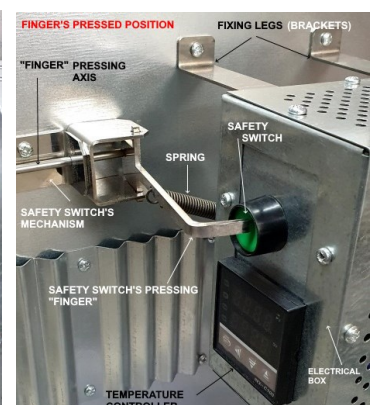

Now connect one end of the tension spring (supplied) to the safety-switch's pressing finger (Pic. 15) and the other to the fixing screw on the electrical box wall that is facing the kiln, as shown in Pic. 14.

- ◆ **IMPORTANT!** After assembling this safety-switch mechanism, ensure the finger firmly **PRESSES** on the **SAFETY SWITCH** when the door is **OPEN** (Pic. 16) and completely **RELEASES** the **SAFETY SWITCH** when the door is **CLOSED** (Pic. 15), otherwise the heating elements will not heat up.

- ◆ Your kiln door has a small ventilation hole with a stainless-steel shutter (Pic. 17).

**Pic. 17:**

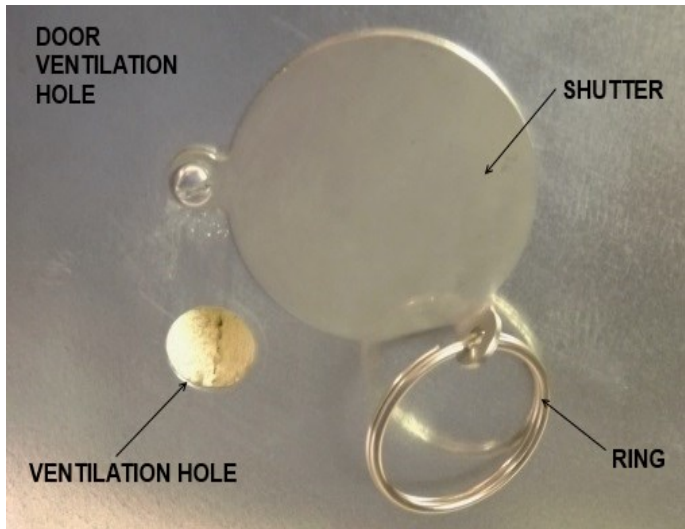

**Pic. 18:**

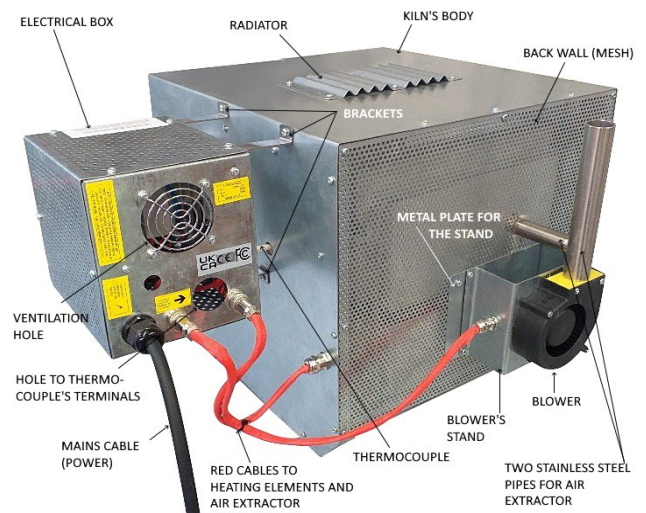

- ◆ To assemble your kiln's extraction system (Pic. 18), please connect the main and internal tubes, then attach the blower's metal stand with the blower and these tubes to the metal plate on the back of the kiln using the four screws. Next, connect the RED blower cable to the appropriate socket on the back of the electrical box. Once assembled, please check that the pipes fit together properly and that the main tube has been properly inserted into the blower to ensure it works effectively.
- ◆ Your kiln is now assembled. Close the door shutter (Pic. 17) to prevent heat leaking out from inside the chamber. Connect the mains cable to a power supply, set the controller and start your project.
- ◆ When using the kiln for the first time, it must be heated up for approximately 70 minutes (factory setting) to allow any water to evaporate from the chamber. Please do not be alarmed if light smoke and/or a smell appears (when using the kiln for the FIRST time). This is normal for new kilns as any water, grease or oils burn out from the heating element(s), shelves, chamber and from inside the kiln. It should not happen again after the first time it is heated. If your kiln is used less than once a month then please repeat this process each time you use it.
- ◆ Please also note that the temperature shown on the controller is the temperature around the thermocouple(s) inside the kiln's chamber. You may have to wait up to two hours for the inside of your kiln to heat up fully and reach the same temperature everywhere inside the chamber.
- ◆ USEABLE CHAMBER DIMENSIONS: Pic. 19 shows FRONT AND TOP VIEW drawings of the kiln's chamber.

**Pic. 19**

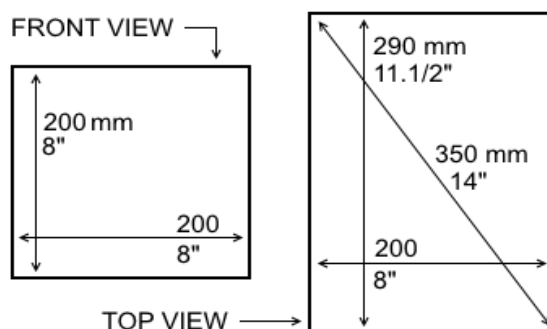

## **TEMPERATURE CONTROLLER:**

The programmable temperature controller (XMTG-7000) has already been set up for chamber drying by the manufacturer (if you have not requested a different setting). If you want to re-program this controller, please refer to the controller's user manual or contact us for help on Skype. Below are some useful tips for using this controller:



1. "SET" – setting/confirmation button (used for setting all of the controller's parameters).
2. "Arrow Left" or "A/M" – segment selector (to choose from four segments).
3. "Arrow Down" – decrease (used to set the required temperature).
4. "Arrow Up" – increase (used to set the required temperature).

**Example program:** Increase from room temperature up to 450°C within 99 minutes, soak at 450°C for 4 minutes and then decrease to room temperature within 145 minutes.

### **Example instructions:**

1. Open your kiln's door to trigger the safety-switch mechanism, which will disconnect the power supply from the heating element(s) and prevent the kiln from heating up while you program the temperature controller. Alternatively, simply press button 4 for 3 seconds until you see "STOP" on the bottom display. Now you can start programming your controller.
  2. Each of the following steps consists of first setting the temperature and then setting the time period in which the NEXT temperature should be reached. There are 32 available input slots each consisting of a pair of temperature and time inputs, i.e. there are a total of 32 temperature inputs alternating with 32 time inputs. To start programming, short-press the 'SET' button.
  3. After you have pressed the 'SET' button, you will set the starting temperature ("C1" on the top display). In this case, input the desired room temperature (usually 20°C), i.e. "0020", into the BOTTOM display using buttons 2, 3 and 4. Now press 'SET' to confirm this initial temperature and to proceed to the next input ("Γ1"). This input is the required TIME to reach the NEXT required temperature. For this example, insert "0099" (99 minutes) into the BOTTOM display, and then press 'SET' again to set this input and to proceed to the next step.
  4. The next step begins by setting the second required temperature ("C2"). To set this, insert "0450" (450°C) into the bottom display. Next, press 'SET' again to proceed to the next input ("Γ2"), where you will set the required time to the NEXT temperature. In this case, this is our soaking time of 4 minutes - "0004". Press 'SET' again to confirm this time and to proceed to the next step.
  5. The next step begins by setting the third required temperature ("C3"), in this case the required soaking temperature. Enter "0450" (450°C) into the bottom display again. Next press 'SET' once more to proceed to the next time input ("Γ3"), which in this case will be 145 minutes. Input "0145" into the bottom display, then press 'SET' again.
  6. For the next step, set the fourth and final required temperature ("C4") – "0020" (20°C).
  7. To indicate the end of the program, press the 'SET' button again, insert "0000" into the bottom display and press the 'SET' button once more. Your program will automatically finish when it reaches this last input.
- A. When you have finished programming the controller, short-press the 'SET' button or simply leave the controller for about 30 seconds for your new setting to be remembered and for your job to start.**
- B. Close the kiln door to disconnect the safety-switch mechanism, allowing your kiln to start heating up. Alternatively, if you pressed button 4 in step 1 above, now press button 3 for 3 seconds until the word "RUN" appears on the bottom display.**
- C. Important: you'll have about 20-30 seconds to change EACH temperature/time setting. Please do not worry if you take too much time and the controller resets and starts displaying the current temperature inside the chamber again. Simply restart the programming process by short-pressing the 'SET' button again. If you are a beginner and are having difficulty programming your controller, please feel free to contact the manufacturer or agent/shop for free help with this matter during the warranty period.**

**SAFETY INSTRUCTIONS and USEFUL TIPS FOR BEGINNERS:**

- ⇒ Please make sure that any item(s) you place inside the chamber are not touching the heating element(s).
- ⇒ It is always best to conduct some tests on a small quantity of your firing material before you fire your item(s).
- ⇒ Re-programming this kiln to use it for temperatures higher than 1,050°C may cause a problem with the heating element(s) and/or with the kiln's metal body that are NOT under warranty.
- ⇒ This kiln should be positioned on a level surface that will not be damaged by heat. A masonry or concrete floor is recommended, but other protective material like a metal or ceramic (tile) sheet may be used. For a small additional charge this kiln can also be supplied with a set of two shelves and a metal stand for placing it on a heat-sensitive worktop.
- ⇒ Always make sure that the door is closed properly in order for the heating element(s) to turn on and for the highest possible temperatures to be reached inside the chamber. Only open/close the door with gloves on.
- ⇒ Always use heat-resistant gloves and long metal tweezers to remove or place item(s) from/into the kiln.
- ⇒ This kiln should be kept away from all inflammable materials and other heating devices.
- ⇒ When the door is open at temperatures higher than 300°C (572°F), always maintain as much distance as possible between you and the hot chamber. Please also wear dark glasses to avoid any problems with your eyes.
- ⇒ Because of the high temperatures that this kiln can reach, you should never leave it unattended when it is in use.
- ⇒ Never touch the kiln's metal body, ventilation tube or shutter on the door without gloves on as these can burn your hands.
- ⇒ KEEP OUT OF REACH OF CHILDREN.
- ⇒ Disconnect the kiln from its power supply when not in use.
- ⇒ The manufacturer reserves the right to make changes to this kiln that improve furnace performance without notification.

**WARNING: This is an electrical, often extremely hot piece of equipment: always follow any applicable health and safety rules and regulations for electrical equipment and hot work in your country.**

**MADE IN THE UK**